

PRELIMINARY ISSUE - NOT FOR MANUFACTURE

APPROVED FOR	SIGNED	DATE
QUOTATION		
MATL ORDER		
MANUFACTURE		
REWORK		

REV.	DESCRIPTION	DATE	APPROVED
REVISION TABLE			

#	NOTES
1	
2	
3	
4	
5	MATERIAL
6	QTY
7	TOT QTY
8	FINISH
9	VENDOR
10	FILE NAME
11	WELDING

**Lanark** VICTORIA - HEAD OFFICE  
 Ph: (03) 9768 2077  
 Fax: (03) 9768 3036  
 Email: [vc@lanark.com.au](mailto:vc@lanark.com.au)

**BATHROOMWARE SPAS & HOT TUBS**

Design by View7

GENERAL TOLERANCE +/- 0.5mm  
 3RD ANGLE  
 DEBUR AND BREAK SHARP  
 U.O.S.

DATE: 29/10/2008  
 SIGNATURE: [Blank]  
 CHECKED: [Blank]  
 DRAWN: VIEW7  
 PROJECT # V774  
 DRAWING # A

PROJECT	CLIENT
V774-21 JULIET 1650	JULIET 1650
UOS ALL FABRICATIONS TO BE FULLY WELDED WITH CORRECT PREPARATION OF WELD SURFACES INCLUDING REVELLED EDGES ETC	DWG NO. V774-21
ALL DIMENSIONS GIVEN UNLESS OTHERWISE SPECIFIED REMAIN THE SOLE PROPERTY OF LANARK AND MAY NOT BE COPIED OR REPRODUCED WITHOUT PERMISSION	SHEET SCALE: 1:3 SHEET 1 OF 2

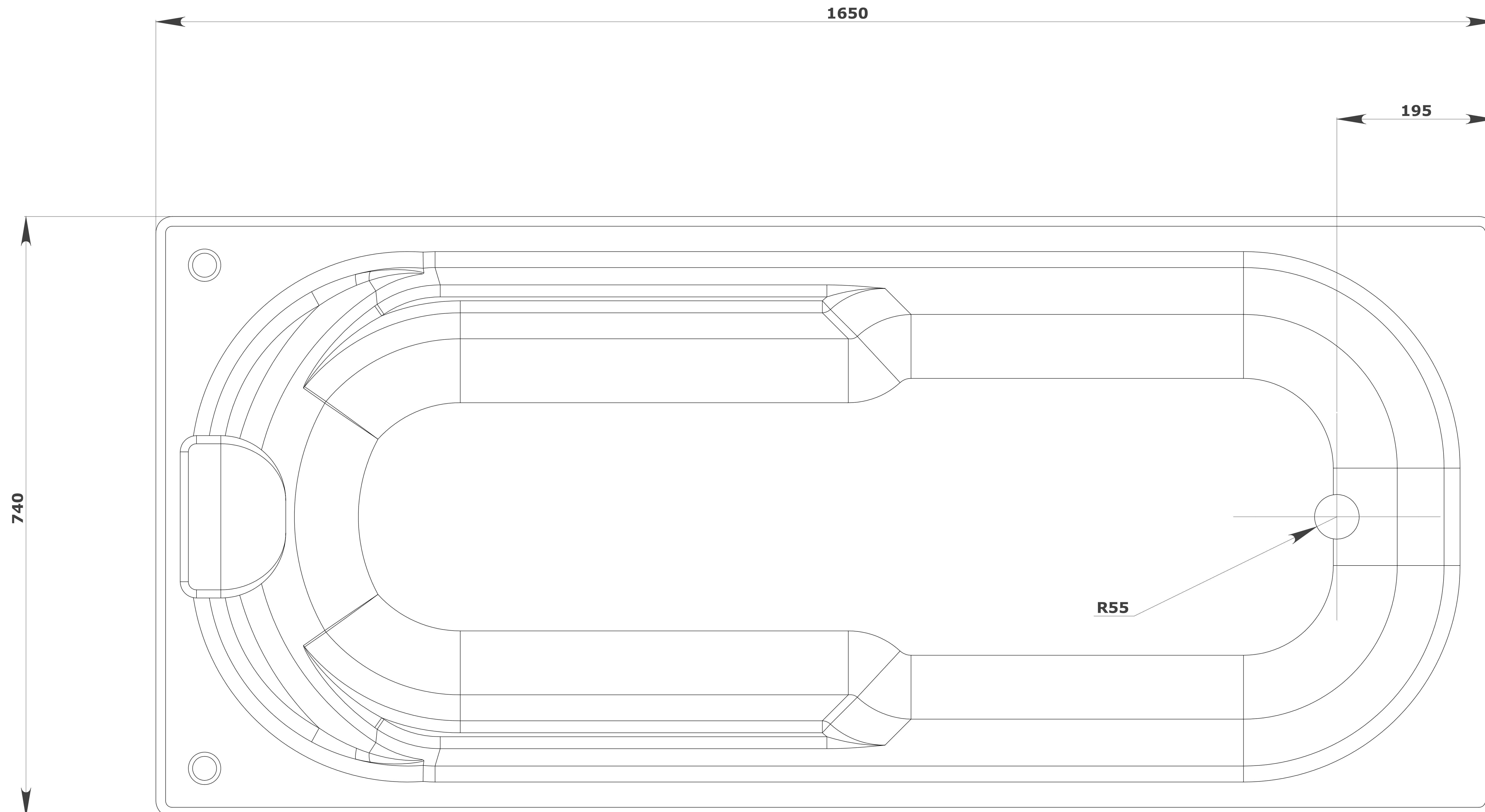

**JULIET 1650**