

REV.	DESCRIPTION	DATE	APPROVED
REVISION TABLE			

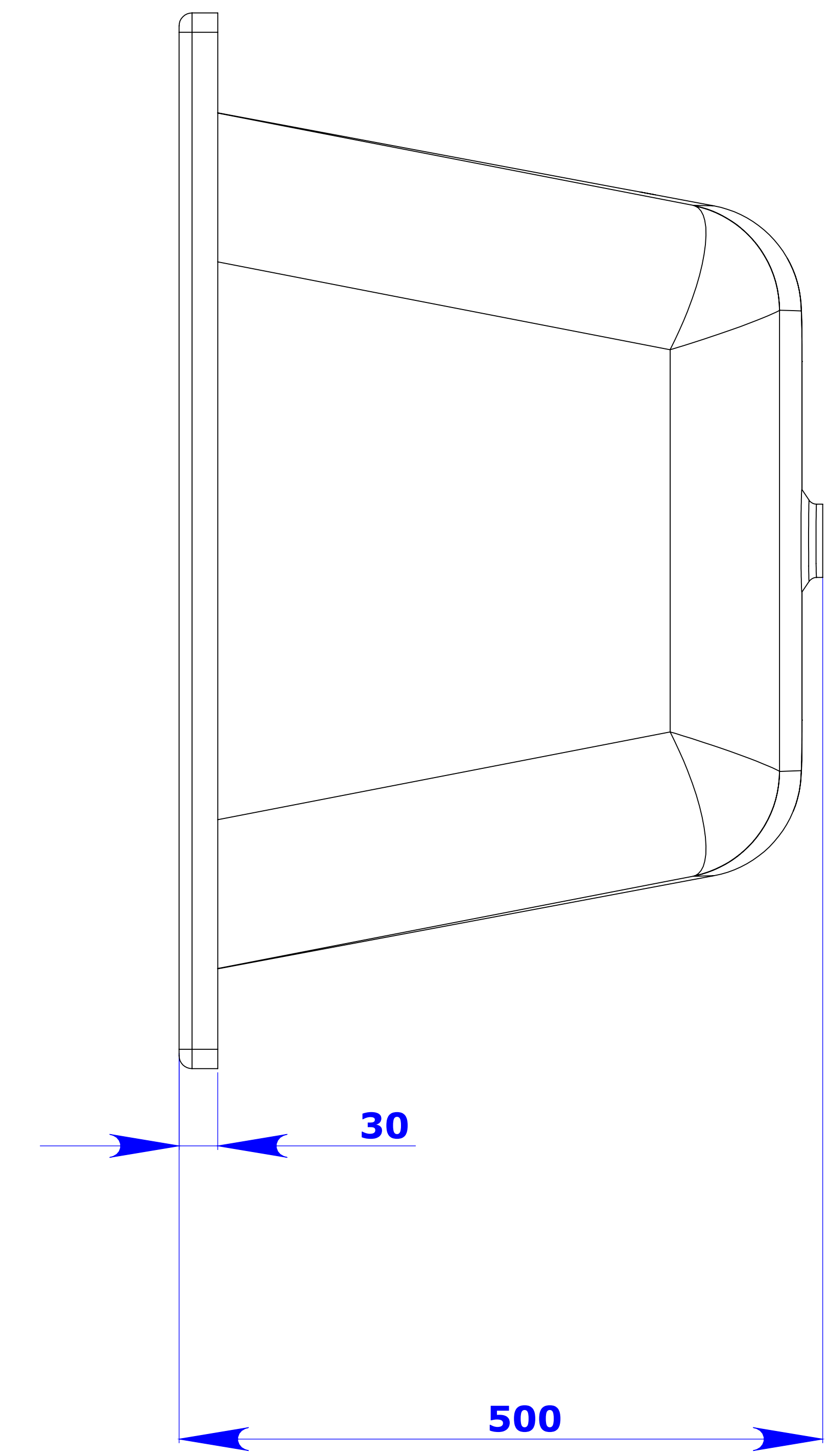
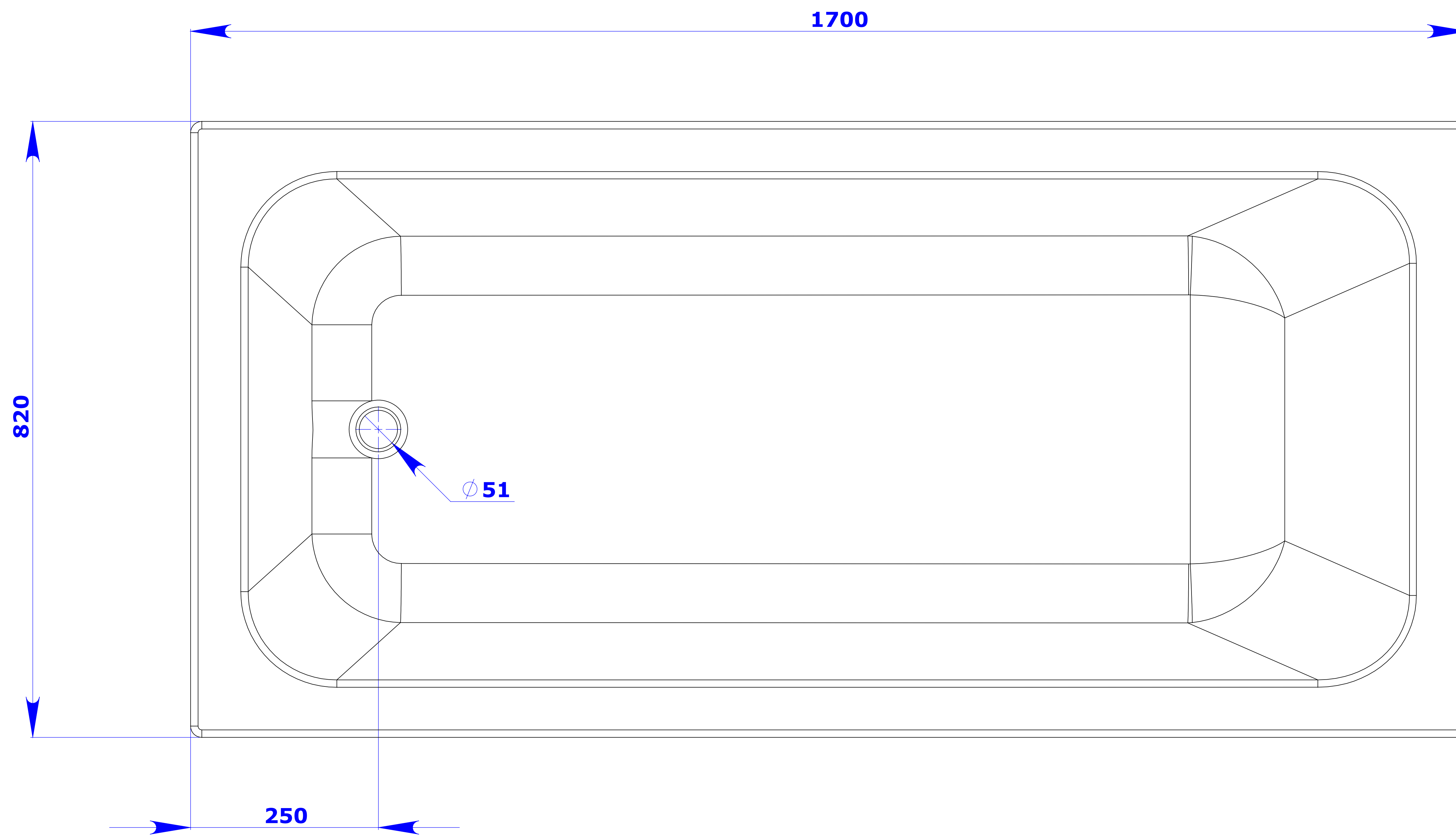

PRELIMINARY ISSUE - NOT FOR MANUFACTURE

APPROVED FOR	SIGNED	DATE
QUOTATION		
MATL ORDER		
MANUFACTURE		
REWORK		

#	NOTES	PROJECT	CLIENT
1		<p><b>Lanark</b> VICTORIA - HEAD OFFICE PH: (03) 9768 2077 FAX: (03) 9768 3036 EMAIL: vcs@lanark.com.au</p> <p>BATHROOMWARE SPAS &amp; HOT TUBS</p> <p>Design by View7</p>	<p>CUSTOMER</p> <p>TITLE: <b>MIZU 1700</b></p> <p>DWG NO: V774-45</p> <p>SHEET SCALE: 1:3 SHEET 1 OF 1</p>
2			
3			
4			
5	MATERIAL Material <not specified>		
6	QTY		
7	TOT QTY		
8	FINISH		
9	VENDOR		
10	FILE NAME v774-45_MIZU 1700		
11	WELDING UOS ALL FABRICATIONS TO BE FULLY WELDED WITH CORRECT PREPARATION OF WELD SURFACES INCLUDING REVELLED EDGES ETC.		

GENERAL TOLERANCE +/- 0.5mm  
3RD ANGLE  
DEBUR AND BREAK SHARP EDGES  
U.O.S.

DRAWN: [Signature] DATE: 20/06/2009  
CHK'D: [Signature]  
APP'D: [Signature]  
WFOGR: [Signature]

DESIGNER: [Signature] V774-45  
DATE: PRE

ALL DIMENSIONS CONTAINED IN THIS DRAWING UNLESS OTHERWISE SPECIFIED ARE THE SOLE PROPERTY OF LANARK AND MAY NOT BE COPIED OR REPRODUCED WITHOUT PERMISSION.